

DESUPER- HEATERS

DESUPERHEATERS

PRESSURES to 600 PSIG at 750°F



- Reduces the temperature of superheated steam by controlled direct injection of cooling water
- Mechanical atomizing 2.5:1 turndown
- Steam atomizing 20:1 turndown
- Line Sizes 3" to 24" (larger sizes available upon request)
- Velocities to 8000 feet per minute

Canadian Registration # OH6267.51

STEAM ATOMIZING DESUPERHEATER

APPLICATION DATA

- Reduce Temperature of Superheated Steam

SIZING INFO
PAGE 280

MECHANICAL ATOMIZING DIMENSIONS, inches (mm) AND WEIGHTS, pounds (kg)

Size	B	H	K	A													Weight
				P = MAIN STEAM PIPE													
				3	3½	4	5	6	8	10	12	14	16	18	20	24	
#1	5 (127)	¼ (6)	2 (51)	7 (178)	7½ (191)	8½ (216)	10 (254)	11 (280)	13 (330)	—	—	—	—	—	—	—	15 (6.8)
#3	4½ (113)	½ (13)	2 (51)	—	—	8½ (216)	10 (254)	11 (280)	13 (330)	15½ (394)	16½ (419)	—	—	—	—	—	22 (10)
#5	5⅝ (130)	1 (25)	4 (102)	—	—	—	—	11 (280)	13 (330)	15½ (394)	16½ (419)	17½ (445)	19½ (495)	—	—	—	40 (18)
#6	7½ (190)	1¼ (32)	4 (102)	—	—	—	—	—	13 (330)	15½ (394)	16½ (419)	17½ (445)	19½ (495)	21½ (546)	—	—	75 (34)
#8	7⅞ (200)	2 (51)	6 (152)	—	—	—	—	—	—	15½ (394)	16½ (419)	17½ (445)	19½ (495)	21½ (546)	23½ (597)	27½ (699)	135 (61)

DESUPERHEATERS

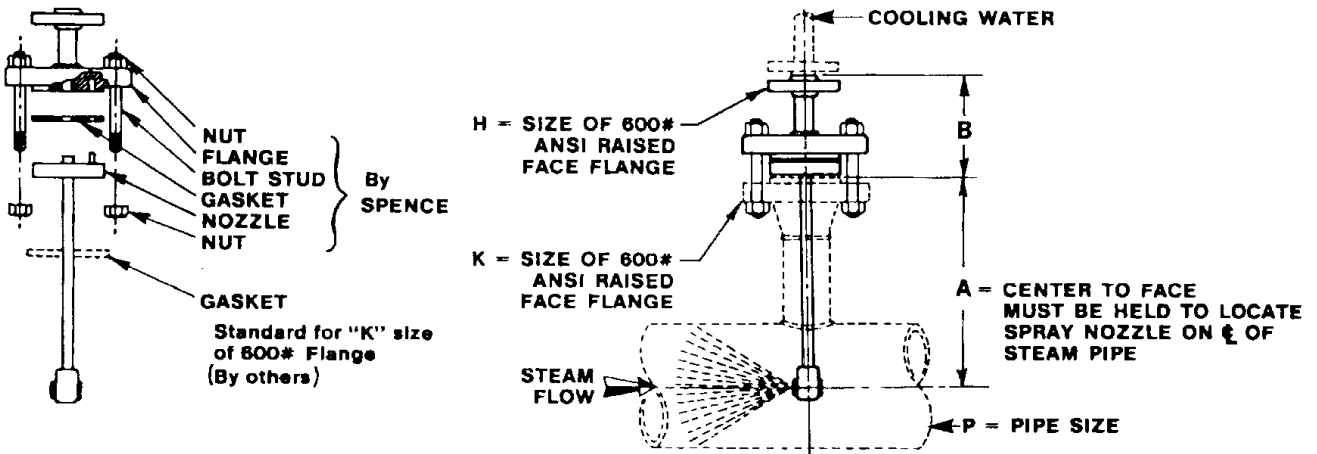

DESUPERHEATERS

SPECIFICATIONS

The Desuperheater shall be air operated, consisting of atomizing injector nozzle, dual controller, air pilot and strainers. It shall be capable of handling wide load variations from full load to 5% of maximum and control within $\pm 5^\circ\text{F}$.

The injector nozzle shall be designed and installed to disperse the minute water particles and atomizing steam counter to the flow of superheated steam, enabling the fine mist to be easily evaporated.

The dual controller shall be so constructed that it will maintain a balanced, modulated flow of steam and water to the injector nozzle at all times and shall be so arranged that the atomizing steam shall lead the water on opening and trail on closing, so that it is impossible for the water to reach the injector nozzle before the steam.



DUAL CONTROL DESUPERHEATER NOZZLE

MATERIALS OF CONSTRUCTION

.....300 Series Stainless Steel

STEAM ATOMIZING DIMENSIONS, inches (mm) AND WEIGHTS, pounds (kg)

Size	B	H	J	K	A													Weight
					P = MAIN STEAM PIPE													
					3	3½	4	5	6	8	10	12	14	16	18	20	24	
#1	5 (127)	¼ (6)	¾ (95)	2 (51)	7 (178)	7½ (191)	8½ (216)	10 (254)	11 (280)	13 (330)	—	—	—	—	—	—	—	18 (8)
#3	5 (127)	½ (13)	⅜ (79)	⅜ (79)	—	—	8½ (216)	10 (254)	11 (280)	13 (330)	15½ (394)	16½ (419)	—	—	—	—	—	28 (13)
#5	5⅞ (148)	1 (25)	4¼ (108)	4 (102)	—	—	—	—	11 (280)	13 (330)	15½ (394)	16½ (419)	17½ (445)	19½ (495)	—	—	—	68 (31)
#6	6¼ (159)	1¼ (32)	6 (152)	5 (127)	—	—	—	—	—	13 (330)	15½ (394)	16½ (419)	17½ (445)	19½ (495)	21½ (546)	—	—	110 (50)
#8	8¼ (210)	2 (51)	7½ (191)	8 (203)	—	—	—	—	—	—	15½ (394)	16½ (419)	17½ (445)	19½ (495)	21½ (546)	23½ (597)	27½ (699)	270 (123)

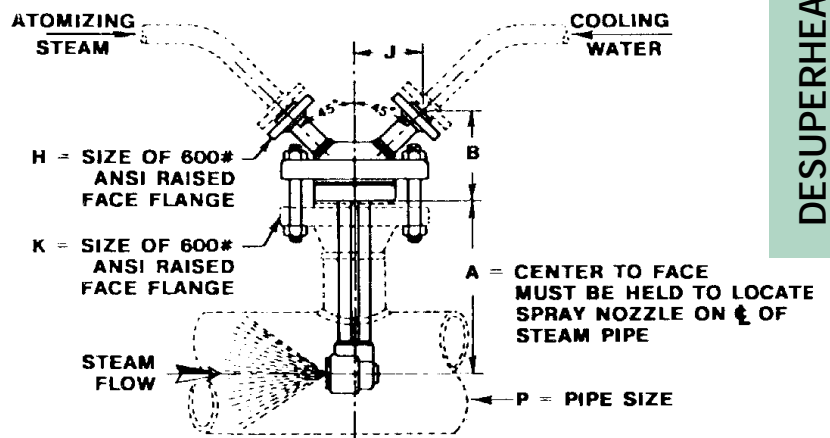
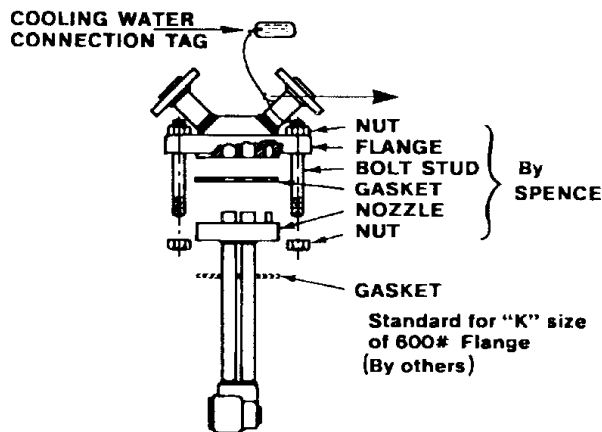

DESUPERHEATERS

RULES FOR SIZING DESUPERHEATERS

The required amount of cooling water to be injected into the superheated steam is the basis on which a Desuperheater size is determined. Since the heat gained by the injected cooling water equals the heat lost by the superheated steam, the required cooling water, G, in gallons per minute is calculated as follows:

$$G = \frac{W_S}{500} \times \frac{h_S - h_D}{h_D - (t - 32)} \text{ gpm}$$

Where: W_S = Superheated steam flow, lb per hour
 h_S = Total heat of the superheated steam, Btu per lb
 h_D = Total heat of the desuperheated steam, Btu per lb
 t = Temperature of the cooling water, °F

The values h_S and h_D may be taken from the Steam Tables on the inside back cover. Having determined the amount of cooling water, G, choice of the size unit may be made directly from the Selection table below.

Cooling water supply pressure must always be at least 75 psig higher than the pressure of the steam being desuperheated.

With Steam Atomizing Desuperheaters, the atomizing steam pressure must always be at least 50 psig higher than the pressure of the steam being desuperheated. Also, when there is more than approximately 100 psig difference between cooling water and atomizing steam pressures, a pressure reduction should be made on the higher of the two.

SELECTION TABLE—STEAM ATOMIZING AND MECHANICAL ATOMIZING DESUPERHEATERS

SIZE NUMBER	DIRECT OPERATED		PILOT OPERATED			
	No. 1	No. 3	No. 3	No. 5	No. 6	No. 8
COOLING WATER CAPACITY, GPM	1.3	4.0	4.0	12	22	52
PIPE CONNECTIONS FOR COOLING WATER AND ATOMIZING STEAM	1/4"	1/2"	1/2"	1"	1 1/4"	2"
MINIMUM SIZE OF MAIN STEAM PIPE	3"	4"	4"	6"	8"	12"

STEAM FOR ATOMIZATION

A source of higher pressure atomizing steam offers no problem on most desuperheater installations. Generally, the steam being desuperheated is at reduced pressure, having either been throttled by a reducing valve or extracted from an intermediate stage of a turbine.

When a pressure reduction is required in conjunction with desuperheating the steam, it is recommended that the reduction take place prior to desuperheating for the following reasons:

1. Auxiliary high pressure steam for atomization is immediately available.

2. The Pressure Regulator is not subject to a damaging accumulation of soluble salts precipitated by evaporation from the cooling water.
3. Elimination of resuperheating when the pressure reduction is after the point of superheat control.

If higher pressure steam is not available, a Mechanical Atomizing Desuperheater must be employed. The Injector Nozzle is identical with the Steam Atomizing Nozzle except that it does not have the advantage of secondary atomization into mist by the action of the steam.